

Detail 1 - GLYDE Universal Bracket - Plan

M8 Bolt:
Alternative Fixing Detail.
See note 2.

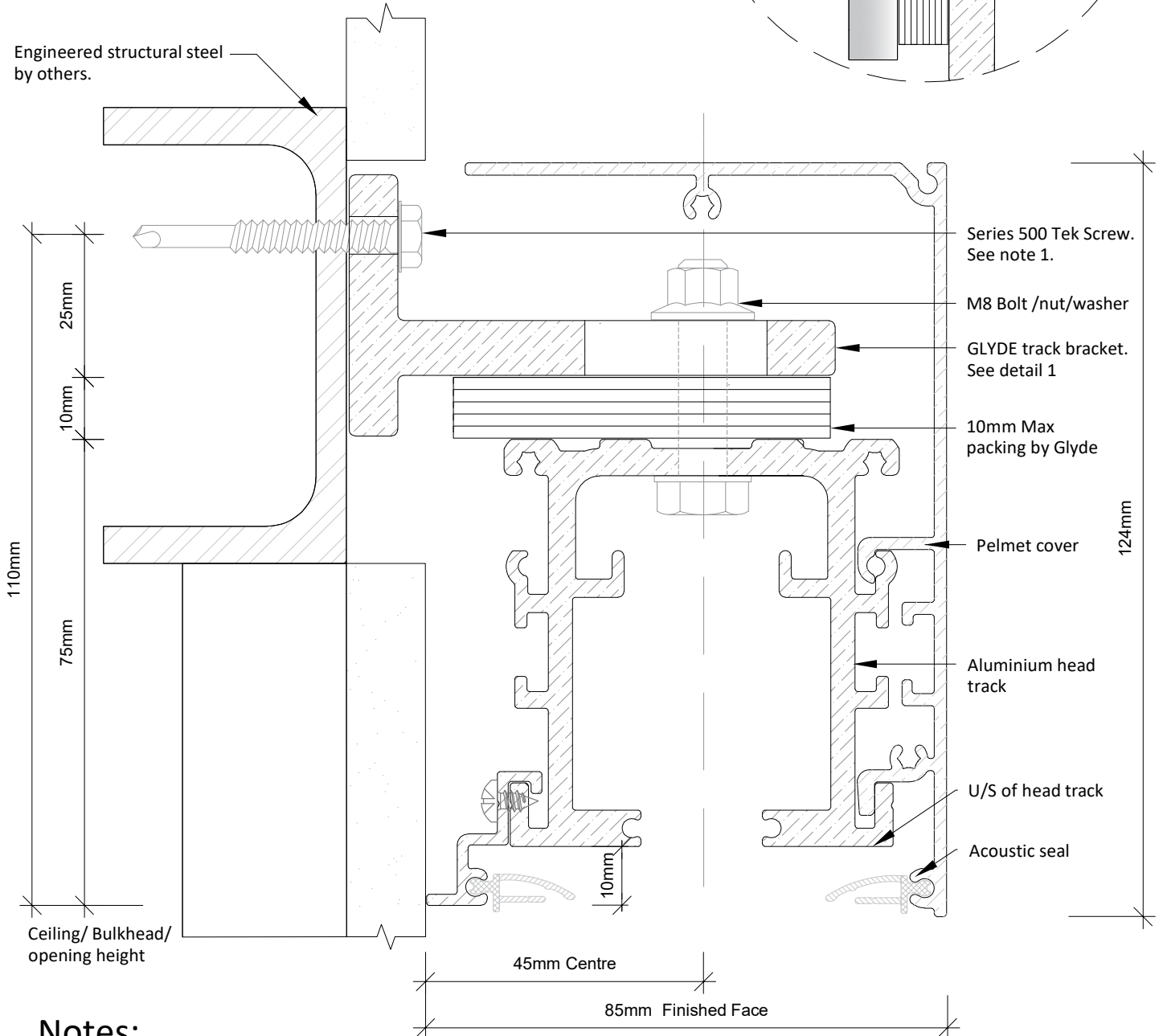
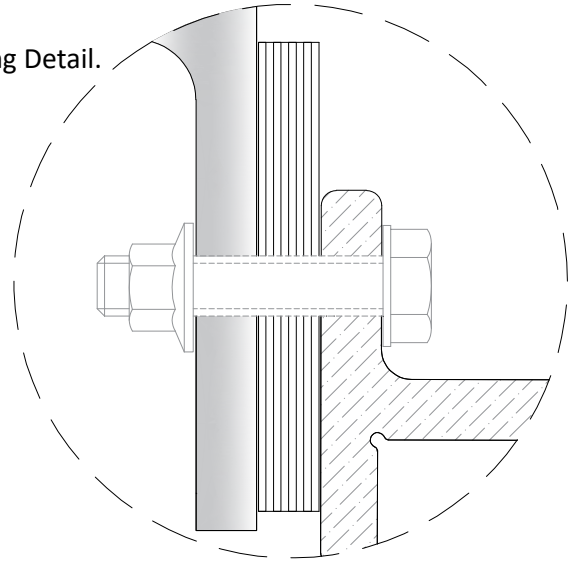

Notes:

1. Preferred Fixing:
2 off 14-20 Teks Pitched 1000mm (fine Thread) fixing through bracket and 5mm min embedment into steel. MAX packing 10mm

2. Alternative Fixing:
M8 - 8.8 Grade fixing and 5mm minimum embedment into steel. Drill Pattern TBC MAX packing 30mm.

3. Structure:
Structural steel designed and certified by others.

GLYDE
GLYDE ARCHITECTURAL ACOUSTIC SYSTEMS
160 OROISH RD, DANDENONG, VIC 3175
TEL: (03) 9798 4433
glydearchitectural.com.au

Product. GLYDE - ACOUSTIC SLIDERS		Description. FACE MOUNT TRACK FIXED TO STEEL PFC	
PROPRIETARY		Drawn AA	Date 1/6/2023
THE INFORMATION CONTAINED IN THIS DRAWING IS THE SOLE PROPERTY OF ALUMINIUM INDUSTRIES OF AUSTRALIA PTY LTD. ANY REPRODUCTION IN PART OR AS A WHOLE WITHOUT THE WRITTEN PERMISSION OF ALUMINIUM INDUSTRIES OF AUSTRALIA PTY LTD IS PROHIBITED.		Drawing No. GD-TD-0007	Revision 2