

M8 Bolt: Alternative Fixing Detail. See note 2.

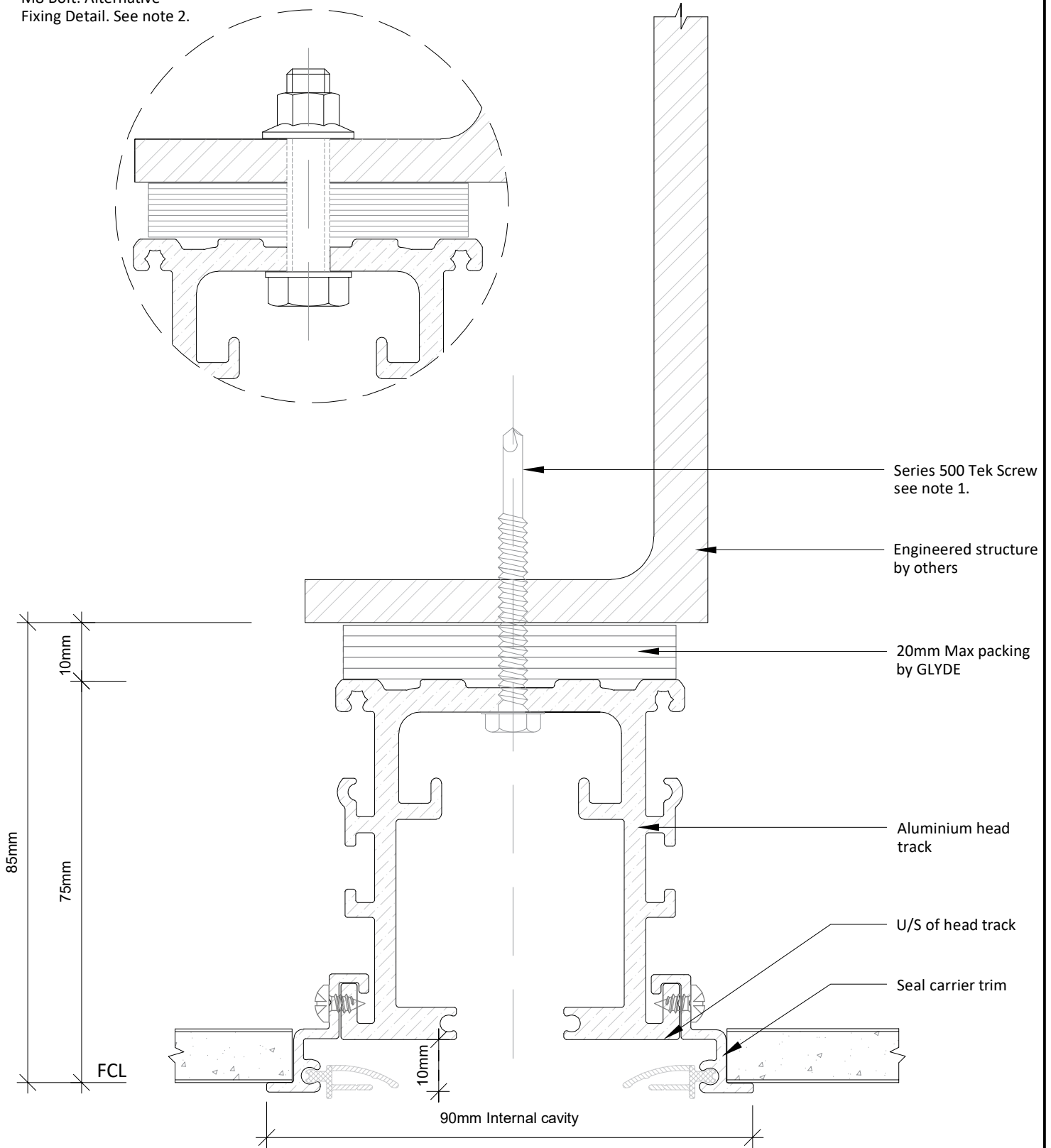

Notes:

1. Preferred Fixing:
 Ø6.5 14-20 Tek's Pitched 1000mm
 (fine Thread) fixing through bracket
 and 5mm min embedment into steel.
 Max packing 20mm

2. Alternative Fixing:
 M8 - 8.8 Grade fixing and 5mm minimum
 embedment into steel. Drill Pattern TBC
 MAX packing 30mm

3. Structure:
 Structural steel designed and
 certified by others.



GLYDE ARCHITECTURAL ACOUSTIC SYSTEMS

160 ORDISH RD, DANDENONG, VIC 3175
 TEL: (03) 9798 4433
 glydearchitectural.com.au

Product. GLYDE - ACOUSTIC SLIDERS		Description. TRACK DIRECT FIX TO PFC	
PROPRIETARY		DRAWN AA	Date 1/6/2023
THE INFORMATION CONTAINED IN THIS DRAWING IS THE SOLE PROPERTY OF ALUMINIUM INDUSTRIES OF AUSTRALIA PTY LTD. ANY REPRODUCTION IN PART OR AS A WHOLE WITHOUT THE WRITTEN PERMISSION OF ALUMINIUM INDUSTRIES OF AUSTRALIA PTY LTD IS PROHIBITED.		DRAWING NO. GD-TD-0001	Revision 2